

# Plaisir d'amour

Jean-Paul-Égide MARTINI

First system of musical notation. The staff shows a sequence of notes and chords. Chord diagrams are provided above the staff: F (02321x), C (0003), and F (02321x). The notation includes a treble clef, a key signature of one flat (B-flat), and a 4/4 time signature. The melody consists of quarter notes and eighth notes. The bass line features a steady eighth-note accompaniment with some double bass notes.

Second system of musical notation. Chord diagrams are provided above the staff: C7 (0003), F (02321x), and C (0003). The notation includes a treble clef, a key signature of one flat (B-flat), and a 4/4 time signature. The melody continues with quarter and eighth notes. The bass line includes a triplet of eighth notes and continues with a steady eighth-note accompaniment.

Third system of musical notation. Chord diagrams are provided above the staff: G7 (x0233x), C7 (x003), F (02321x), and Gm (02321x). The notation includes a treble clef, a key signature of one flat (B-flat), and a 4/4 time signature. The melody continues with quarter and eighth notes. The bass line includes a triplet of eighth notes and continues with a steady eighth-note accompaniment.

Fourth system of musical notation. Chord diagrams are provided above the staff: F (02321x), C (0003), and F (02321x). The notation includes a treble clef, a key signature of one flat (B-flat), and a 4/4 time signature. The melody concludes with quarter and eighth notes. The bass line includes a triplet of eighth notes and continues with a steady eighth-note accompaniment. The word *fin* is written at the end of the staff.

1°

**F** **Bb** **F** **Bb**

5 5 5 5 5 5 7 5 6 5 6 5 5 5 7 8 7 5 6 6 6 5 5 7 5

1° **F** **C7** **F**

5 5 5 5 5 5 3 0 0 0 0 2 0 1 0 1 0 0 1 0 1 0

1° **G** **C** **Dm** **Dm**

2 2 2 2 2 2 3 0 0 4 0 5 5 5 7 8 7 5 9 7 5

1° **C** **G** **C** **C7**

3 0 0 0 2 2 2 2 3 0 0 0 0 1 0 0 0

2°

**Fm** 

**C** 

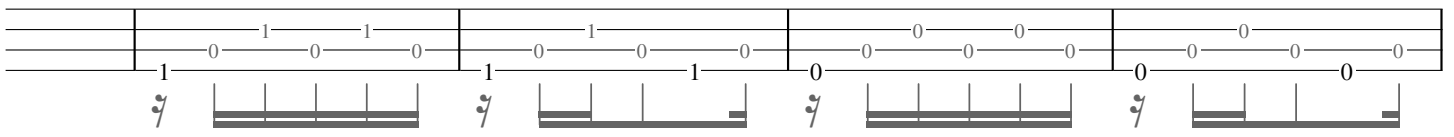

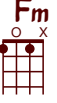

**Fm** 

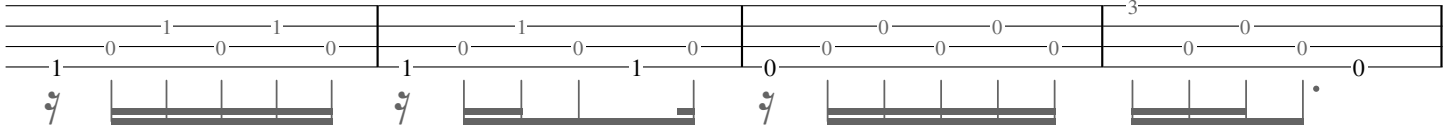
**C** 

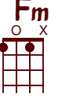

**Fm** 

**E♭** 

**A♭** 

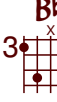
**B♭m** 

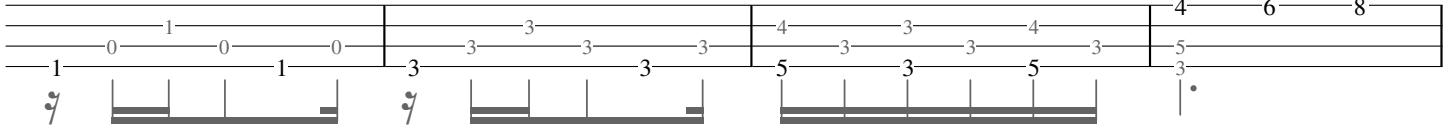

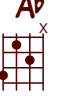

**A♭** 

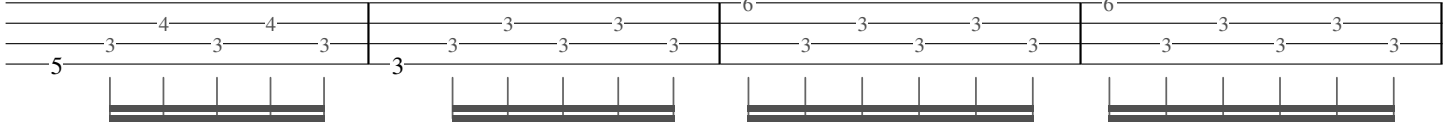
**E♭** 

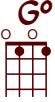
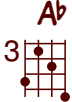



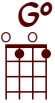

Musical notation for the first system, showing a sequence of chords and fingerings. The notation includes a treble clef, a single sharp (F#), and a 4/4 time signature. The first measure contains a G° chord (0 2 0 0 0 0) with a quarter note on the 1st fret of the 1st string. The second measure contains a G° chord with a triplet of notes (1 3 4) on the 1st string. The third measure contains an A♭ chord (3 2 0 0 0 0) with a quarter note on the 6th fret of the 1st string. The fourth measure contains an A♭ chord with a triplet of notes (3 4 4) on the 1st string. The fifth measure contains an A♭ chord with a triplet of notes (0 3 4) on the 1st string.

Musical notation for the second system, showing a sequence of chords and fingerings. The notation includes a treble clef, a single sharp (F#), and a 4/4 time signature. The first measure contains a G° chord with a triplet of notes (1 1 1) on the 1st string. The second measure contains a G° chord with a triplet of notes (1 3 4) on the 1st string. The third measure contains an A♭ chord with a quarter note on the 6th fret of the 1st string. The fourth measure contains an A♭ chord with a triplet of notes (0 3 4) on the 1st string. The fifth measure contains an A♭ chord with a triplet of notes (4 0 3) on the 1st string.

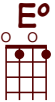
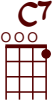
Musical notation for the third system, showing a sequence of chords and fingerings. The notation includes a treble clef, a single sharp (F#), and a 4/4 time signature. The first measure contains an E° chord (0 2 0 0 0 0) with a quarter note on the 1st fret of the 1st string. The second measure contains an E° chord with a triplet of notes (1 1 0) on the 1st string. The third measure contains an Fm chord (1 0 0 0 0 0) with a quarter note on the 1st fret of the 1st string. The fourth measure contains an Fm chord with a triplet of notes (1 1 3) on the 1st string. The fifth measure contains an Fm chord with a triplet of notes (1 0 1) on the 1st string.

Musical notation for the fourth system, showing a sequence of chords and fingerings. The notation includes a treble clef, a single sharp (F#), and a 4/4 time signature. The first measure contains a C7 chord (0 0 0 2 0 0) with a quarter note on the 2nd fret of the 1st string. The second measure contains an Fm chord (1 0 0 0 0 0) with a quarter note on the 1st fret of the 1st string. The third measure contains a C7 chord with a triplet of notes (0 0 0) on the 1st string. The fourth measure contains a C7 chord with a triplet of notes (0 0 0) on the 1st string. The fifth measure contains a C7 chord with a triplet of notes (0 0 0) on the 1st string. The notation ends with a double bar line and the text "→ début → fin".